

# FURUNO®

## Revolutionary heading sensor SATELLITE COMPASS Model SC-50



Radome Antenna

Open Antenna



The future today with FURUNO's electronics technology.

**FURUNO ELECTRIC CO., LTD.**

9-52 Ashihara-cho, Nishinomiya City, Japan Phone: +81 (0)798 65-2111

Fax: +81 (0)798 65-4200, 66-4622 URL: [www.furuno.co.jp](http://www.furuno.co.jp)

Catalogue No. N-857a

TRADE MARK REGISTERED  
MARCA REGISTRADA

Furuno's advanced GPS technology ensures highly accurate heading data for AIS, ECDIS, Radar/ARPA and more.



Compass Rose Mode

- Heading information for radar, AIS, Scanning Sonar, VideoPlotter
- Heading accuracy  $\pm 1.0^\circ$  complying with IMO MSC.116(73) as a THD (Transmitting Heading Device)
- Excellent follow-up rate of 45°/s exceeding requirements for high speed craft (20°/s)
- Accurate SOG, COG, ROT, and L/L
- Pitch and roll output in both analog and digital formats for ship's motion correction
- High speed heading data output in IEC 61162-2 format
- Clear 4.5" silver bright LCD
- Free from regular maintenance
- Tri-antenna system reduces the effect of pitching, rolling and yawing

The SC-50 is a new satellite compass that uses Furuno's advanced GPS technology. This satellite compass can be used for a wide range of applications for any type of vessel. Radar/ARPA, AIS, ECDIS, Scanning Sonar and Autopilots can utilize the functions of this compass. As the SC-50 uses GPS carrier frequency to determine heading, the performance is not affected by ship's speed, latitude, geomagnetism, etc. Settling time is quite instantaneous and the follow-up performance is excellent, achieving 45°/s (SOLAS HSC Code requires 20°/s as a minimum).

This satellite compass delivers GPS positioning, SOG (Speed Over Ground), COG (Course Over Ground) and ROT (Rate of Turn). SOG is remarkably accurate through decoding the Doppler shift in the received satellite signals. The information can be output in IEC61162-2 format at the high update rate up to 38.4 kbps to satisfy the high speed data-output requirements in special applications.

The roll and pitch angle is also output both in analog and digital formats to external equipment. For sonar or echo sounder, the SC-50 offers stable echo pictures by compensating the transmitted/received beams even in

rough seas. Thus, the SC-50 can also function as a highly accurate motion sensor.

The SC-50 has a unique Set and Drift mode. When connected with a water-tracking speed log, such as the DS-80, it calculates set and drift (tide direction and speed) in the mode. The display helps a radar operator manually enter set and drift for the accurate sea stabilization pictures.

The SC-50 consists of Antenna Unit, Display Unit and Processor Unit. The antenna is selectable from an open antenna, defying heavy snowfalls, or a stylish Radome antenna. Each accommodates three GPS antennas. The tri-antenna system helps reduce the influence of vessels' motions rather than dual-antenna system.



Processor Unit





Steering Mode



NAV Data Mode



Heading Mode

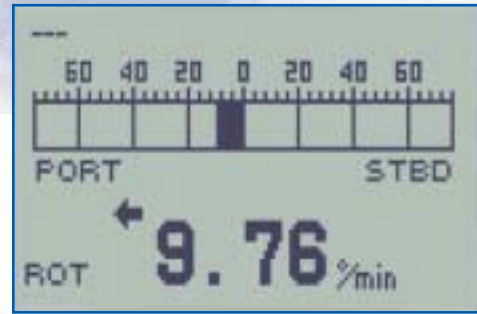

ROT Mode

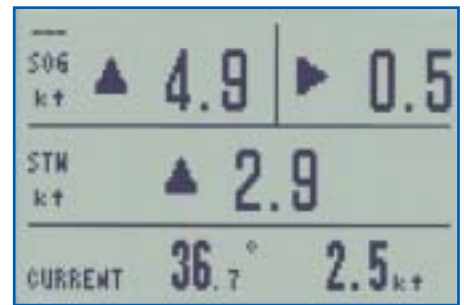

Set & Drift Mode

(Current (Set and Drift) and Distance Run is selectable.)

## Principle

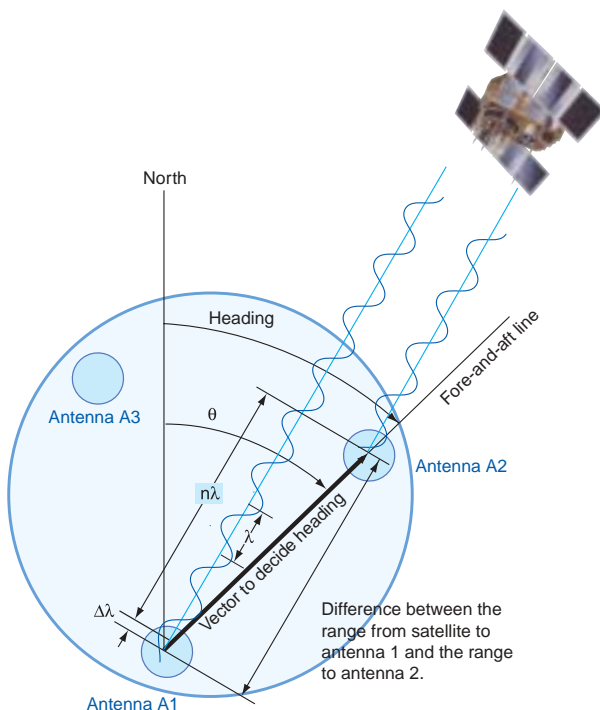

With the SC-50, a ship's heading is determined by decoding the phase data in the GPS carrier frequency. In principle, a pair of antennas A1(ref) and A2(fore), each connected with an associated GPS engine and processor, are installed along the ship's fore-aft line. The GPS systems at A1 and A2 calculate the range and azimuth to the satellite.

The difference in range between A1 and A2 is  $\Delta\lambda + n\lambda$  where  $\lambda$  is 19 cm and  $n^*$  is automatically found during the initialization stage. A fraction of a carrier wavelength,  $\Delta\lambda$ , is processed by Furuno's advanced kinematic technology in geographical survey, thus determining a vector (range and orientation) A1 to A2, i.e., heading of ship relative to north.

In reality, the third antenna is added to reduce the influence of pitch, roll and yaw, and five satellites are used to process 3D data (by 3rd sat), to reduce clock derived error (by 4th sat), and to calculate  $n$  in initial stage (by 5th sat).

If the GPS signal is blocked by a tall building or under a bridge, the 3-axis vibrating-gyro rate sensors in the processor unit take the place of the satellite until all five satellites are in view. The rate sensors also contribute to regulating the heading data against pitch, roll and yaw together with the third antenna (A3 in the illustration).

\*Ambiguity "n" is resolved by LAMBDA algorithm developed by Prof. Teussen, Delft University of Technology, The Netherlands.

# SPECIFICATIONS OF SC-50

## 1. Accuracy

Heading	±1.0° (95% static accuracy) (IMO THD MSC.116(73) static accuracy: ±1.0° x secant Lat.)
GPS Fix	10 m (95%)
DGPS Fix	5 m (95%)
WAAS Fix	3 m (95%)

## 2. Follow-up

45°/s rate-of-turn

## 3. Settling time

3 min

## 4. Interface

Number of ports	5 ports in AD-10 or 10 ports in IEC 61162-1/-2
10 ports*	* can be utilized in menu selection
1 port	AD-10 only
Serial data sentence	25, 100, 200 ms, 1, 2 s data rate: HDT, HDM(Heading), ROT(Rate of turn) ATT(Pitch and Roll) 1, 2 s data rate: VHW(Heading), VTG, VBW(SOG), GGA, GLL, GNS(L/L), ZDA(UTC), VDR( Set and Drift)
Log Output	1 port: 200/400 p/nm (closure)
Alarm Output	1 port: Alarm signal (closure signal)
Heading Input	1 port: Backup Heading (AD-10/IEC 61162-1) HDT, HDG, HDM, VBW, VHW, VLW
DGPS Input	1 port: RTCM SC-104 format

## 5. Receiver Type

Twelve discrete channels.  
C/A code, all-in-view

## 6. Receive Freq

L1 (1575.42 MHz)

## 7. Display Unit

Monochrome LCD, 4.5" diagonal  
95 (W) x 60 (H)mm, 120 x 64 pixels

## 8. Display Mode

Steering, Nav Data, Compass Rose,  
ROT, Heading and Set and Drift modes

**POWER SUPPLY** 12-24 VDC, 15 W

## ENVIRONMENTAL

IEC 60945 for EMC, Vibration, Temperature

## EQUIPMENT LIST

### Standard

- |  |        |
|--|--------|
| 1. Display Unit SC-502                           | 1 unit |
| 2. Antenna Unit SC-303 or SC-603 with 15 m cable | 1 unit |
| 3. Processor Unit SC-501                         | 1 unit |

### Option

- |  |
|--|
| 1. Antenna Cable, 30 m CP20-01700, 50 m CP20-01710 |
| 2. Flush Mount Kit S type CP20-17, F type CP20-29  |

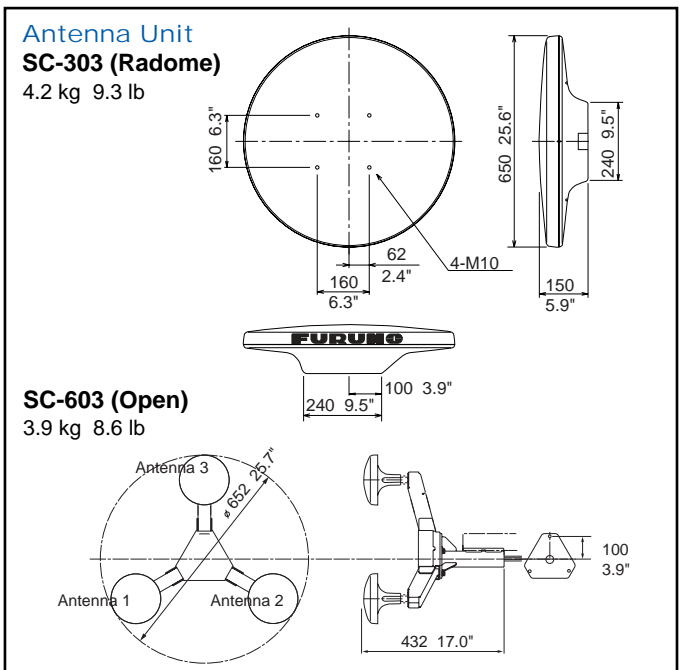
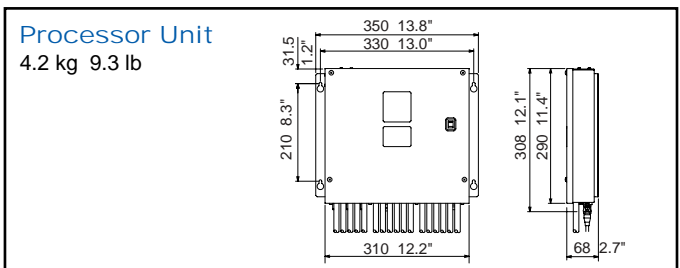
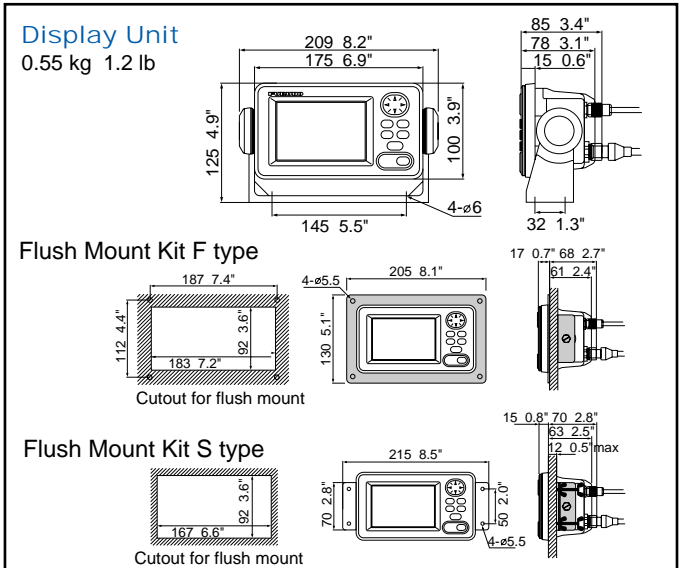

## Interconnection Diagram

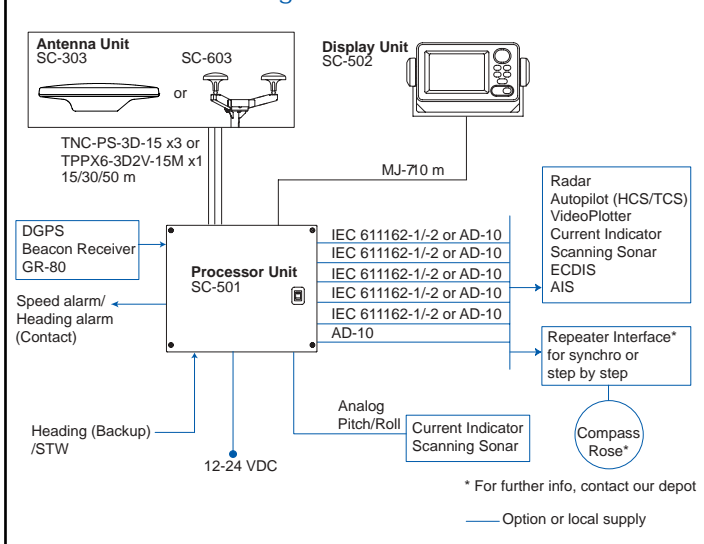

SPECIFICATIONS SUBJECT TO CHANGE WITHOUT NOTICE

**FURUNO U.S.A., INC.**  
Camas, Washington, U.S.A.  
Phone: +1 360-834-9300 Fax: +1 360-834-9400

**FURUNO (UK) LIMITED**  
Denmead, Hampshire, U.K.  
Phone: +44 2392-230303 Fax: +44 2392-230101

**FURUNO FRANCE S.A.**  
Bordeaux-Mérignac, France  
Phone: +33 5 56 13 48 00 Fax: +33 5 56 13 48 01

**FURUNO ESPANA S.A.**  
Madrid, Spain  
Phone: +34 91-725-98-88 Fax: +34 91-725-98-97

**FURUNO DANMARK AS**  
Hvidovre, Denmark  
Phone: +45 36 77 45 00 Fax: +45 36 77 45 01

**FURUNO NORGE A/S**  
Ålesund, Norway  
Phone: +47 70 102950 Fax: +47 70 127021

**FURUNO SVERIGE AB**  
Västra Frölunda, Sweden  
Phone: +46 31-7098940 Fax: +46 31-497093

**FURUNO FINLAND OY**  
Espoo, Finland  
Phone: +358 9 4355 670 Fax: +358 9 4355 6710

04085SS Printed in Japan

